

# Лист запасных частей CN90

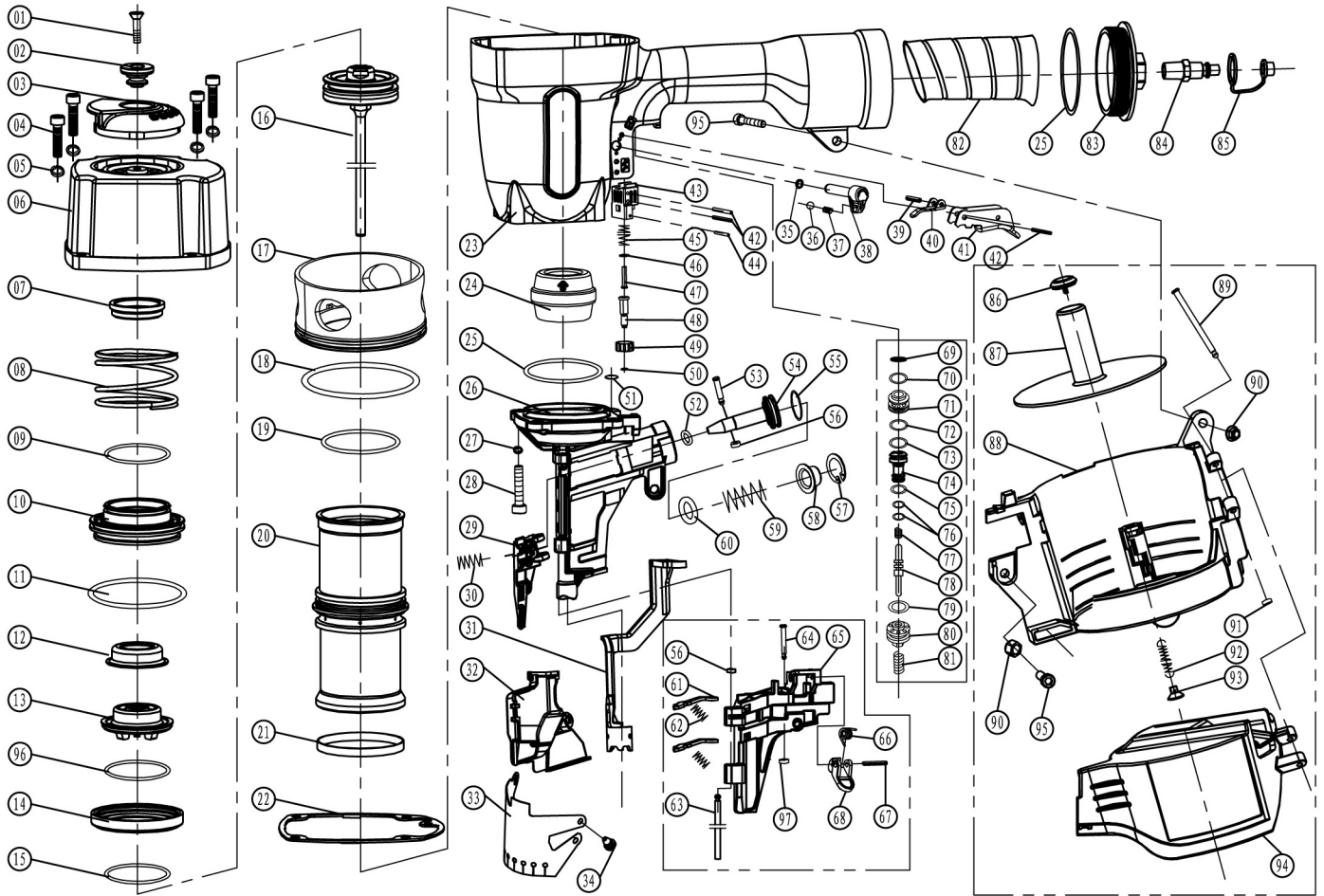

No.	Description	Qty.	No.	Description	Qty.	No.	Description	Qty.	No.	Description	Qty.
01	Bolt M6*25	1	26	Driver guide	1	51	O-ring 7.5*1.8	1	76	O-Ring 2.5*1.5	2
02	Shaft sleeve	1	27	Spring washer 8	4	52	O-ring 9.9*2.4	1	77	Switch Spring	1
03	Air Deflector	1	28	Bolt M8*25	4	53	Washer	1	78	Switch Level	1
04	Bolt M6*35	4	29	Pawl	1	54	Shaft pin	1	79	O-Ring 18*2.65	1
05	Spring washer 6	4	30	Compressed spring	1	55	O-ring 20*2.4	1	80	Switch Seat	1
06	Cylinder Cover	1	31	Safety yoke	1	56	Pin bush	2	81	Compressed Spring	1
07	Washer	1	32	Nailer Head Cover	1	57	Internal circlip	1	82	Handle Cover	1
08	Compressed Spring	1	33	Gun head cover	1	58	Spring Seat	1	83	End cap	1
09	O-ring 45*2.65	1	34	Fixed ring	1	59	Send nail spring	1	84	Air Inlet Plug	1
10	Valve	1	35	Snap retainer 5	1	60	Buffer ring	1	85	Plug Cap	1
11	O-Ring 56*3.55	1	36	Steel ball Dw=3	1	61	Stop nail block	2	86	Spring cover	1
12	Bumper bush	1	37	Compressed spring	1	62	Compressed spring	2	87	Nail Plate	1
13	Cylinder cover bumper	1	38	Adjusting stem	1	63	Shaft pin	1	88	Magazine	1
14	Sealing washer	1	39	Pin 3*18	1	64	Movable cover pin	1	89	Shaft	1
15	O-Ring 57.6*4.5	1	40	Safety spacer	1	65	Movable cover	1	90	Nut M6	2
16	Piston Assembly	1	41	Trigger A	1	66	Torsional spring	1	91	Pin bush	1
17	Collar	1	42	Pin 3*32	3	67	Spring Seat	1	92	Spring	1
18	O-ring 73*3.55	1	43	Adjust seat	1	68	Trigger	1	93	Hook seat	1
19	O-Ring 50*3.55	1	44	Pin 2.5*22	1	69	O-ring 15*2.65	1	94	Magazine cover	1
20	Cylinder	1	45	Compressed spring	1	70	O-Ring 16*1.6	1	95	Bolt M6*30	2
21	Sealing ring	1	46	Gasket	1	71	Valve Seat	1	96	O-ring 50*1.8	1
22	Gasket	1	47	Push Lever	1	72	O-Ring 6.1*1.8	1	97	Pin bush	1
23	Gun Body	1	48	Adjust screw	1	73	O-Ring 6.4*2	1			
24	Bumper	1	49	Adjust nut	1	74	Valve Case	1			
25	O-Ring 63*2.65	2	50	Snap retainer	1	75	O-Ring 9*1.8	1			