

OPERATING INSTRUCTIONS AND PARTS MANUAL

# MODEL R-45

## Coil Nailer

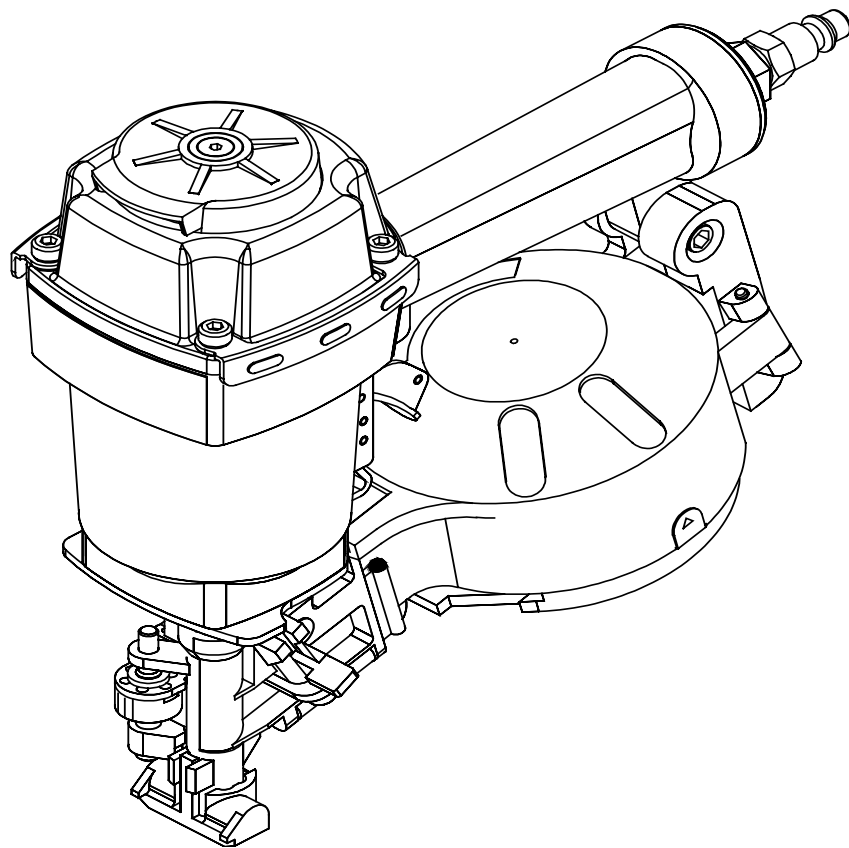

CAREFULLY READ THIS MANUAL BEFORE OPERATING TOOL

**APLUS Pneumatic Corp.**  
NO.579, SEC. 1, SHEN LIN RD., TAYA, TAICHUNG CITY 428 TAIWAN, R.O.C.  
Tel: 886-4-25602860 Fax: 886-4-25602859  
Original instructions

OPERATING INSTRUCTIONS AND PARTS MANUAL

# MODEL R-45

## Coil Nailer

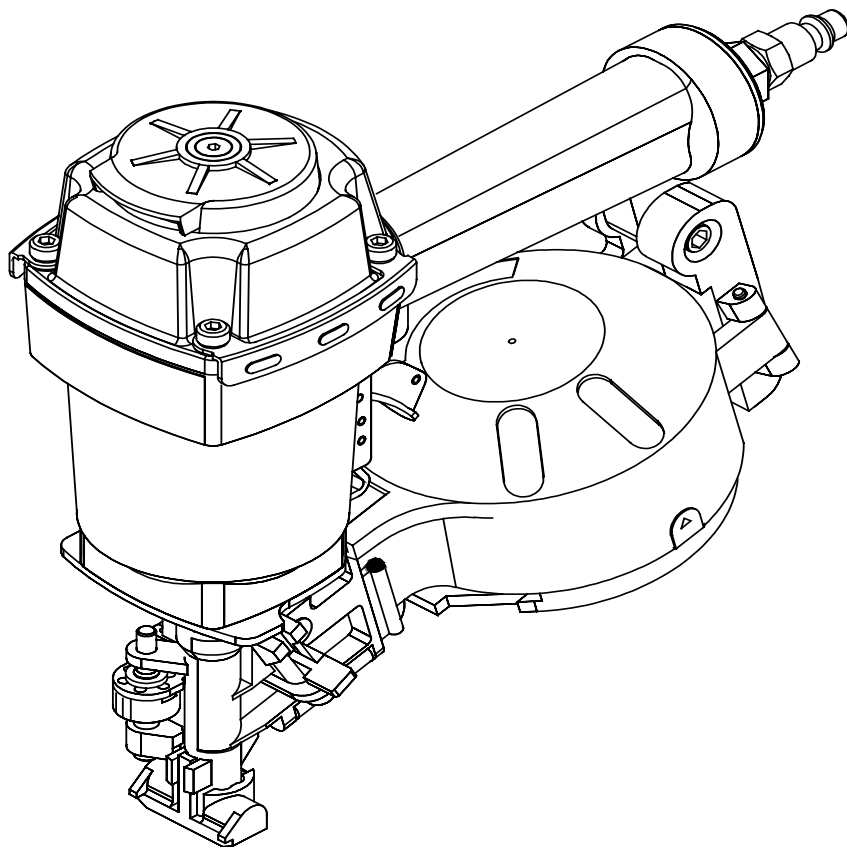

CAREFULLY READ THIS MANUAL BEFORE OPERATING TOOL

## TOOL SPECIFICATIONS

MODEL OF TOOL .....	R-45
TOOL LENGTH .....	11.81" (300 mm)
TOOL HEIGHT .....	10.04" (255 mm)
TOOL WIDTH .....	4.53" (115 mm)
WEIGHT (WITHOUT FASTENERS) .....	5.4 lbs (2.4 kg)
AIR INLET .....	1/4" NPT
<b>COMPRESSED AIR :</b>	
Maximum permissible operating pressure .....	115 PSIG (8 bar)
Recommended operating pressure range .....	75 ~ 110 PSIG (5 ~ 7.5 bar)
AIR CONSUMPTION.....	0.042 scfm with 25 nails per minute @ 100 psi (6.9 bar)

Noise dB(A) :	
A-weighted sound pressure level LpA.....	86.14 dB(A)
A-weighted sound power level LwA.....	99.14 dB(A)
Measurement uncertainty: 3dB	
Vibration (m/s <sup>2</sup> ) :	
Hand-arm vibration value.....	4.41 m/s <sup>2</sup>
Measurement uncertainty: 1.5 m/s <sup>2</sup>	

### Warning:

The vibration emission during actual use of the power tool can differ from the declared total value depending on the ways in which the tool is used; and of the need to identify safety measures to protect the operator that are based on an estimation of exposure in the actual conditions of use (taking account of all parts of the operation cycle such as the times when the tool is switched off and when it is running idle in addition to the trigger time).

List of fasteners for R-45 :

Shank Dia.	Head Dia.	MAGAZINE
φ 3.1 mm , φ 0.12 "	φ 10.0 mm , φ 0.39 "	120 pcs

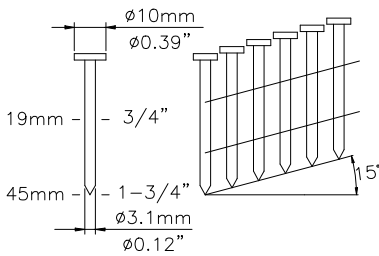

### Foreword:

This pneumatic coil nailer is designed for blocking, pallet making and crate and box assembling. Its well balanced, ergonomic, comfort non-slip cushioned grip and heavy duty driving compatible staples to proper applications ensure you a satisfactory tackle and enjoy work. Fast speed improves work efficiency.

### Suitable applications:

Blocking, pallet making, crate and box assembling.

### Caution:

Coil nailers are only applying on wood. Not suitable for stapling or nailing into concrete, masonry bricks or steel. Do not fire if staples are jammed, as this will cause damage to the relevant parts.



Indicates an imminently hazardous situation which, if not avoided, will result in death or serious injury.



Indicates a potentially hazardous situation which, if not avoided, will result in death or serious injury.

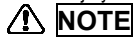

Alerts the operator to useful information.

## SAFETY INSTRUCTIONS



1. Read this manual and understand all safety instructions before operation the tool. If you have any questions, please contact our authorized representatives.
2. Only those fasteners listed in the operating instructions may be used in the fastener driving tools.
3. Only the main energy and the lubricants listed in the operating instructions may be used.
4. Fastener driving tools marked with an inverted equilateral triangle standing on one point may only be used with an effective safety yoke.
5. Fastener driving tools equipped with contact actuation or continuous contact actuation, marked with the symbol " Do not use on scaffoldings, ladders", shall not be used for specific application for example:
  - when changing one driving location to another involves the use of scaffoldings, stairs, ladders, or ladder alike constructions, e.g. roof laths,
  - closing boxes or crates,
  - fitting transportation safety systems e.g. on vehicles and wagons.
6. For the maintenance of fastener driving tools, only spare parts specified by the manufacturer or his authorized representative shall be used.
7. Repairs shall carried out by agents authorized by the manufacturer or by other specialists, having due regard to the information given in the operating instruction.
8. Stands for mounting the fastener driving tools to a support for example a work table shall be designed and constructed by the stand manufacturer in such a way that the fastener driving tool can be safely fixed for the intended use, thus for example avoiding damage,

distortion or displacement.

9. Fastener driving tools operated by compressed air shall only be connected to compressed air lines where the maximum allowable pressure cannot be exceeded by a factor of more than 10%, which can for example be achieved by a pressure reduction valve which includes a downstream safety valve.
10. When using fastener driving tools operated by compressed air, particular attention must be paid to avoid exceeding the maximum allowable pressure.
11. When using fastener driving tools operated by compressed air should only be operated at the lowest pressure required for the work process at hand, in order to prevent unnecessarily high noise levels, increased wear and resulting failures.
12. Hazards caused by fire and explosion when using oxygen or combustible gases for operating compressed air operated fastener driving tools.
13. Carry the fastener driving tool at workpiece using only the handgrip, and never with the trigger actuated. Never carry the tool by the hose or pull the hose to move the tool.

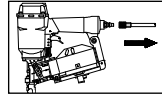

14. Disconnect the tool from air supply before cleaning jams, servicing, adjusting, and during non-operation.



15. Wear eye protection.

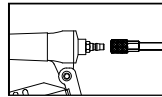

16. Do not use a check valve or any other fitting which allows air to remain in the tool.



17. Do not place your hand or any part of your body in the fastener discharge area of the tool when connecting or disconnecting air supply.



18. Never point tool at yourself or at any other person.



19. Do not use on scaffoldings, ladders.

## AIR SUPPLY AND CONNECTION

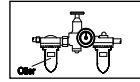

• Many air tool users find it convenient to use oiler to help provide oil circulation through tool and increase the efficiency and useful life of the tool. Check oil level in the oiler daily.

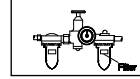

• Many air tool user find it convenient to use a filter to remove liquid and impurities which can rust or wear internal parts of the tool. A filter also increase the efficiency and useful of the tool. The filter must be checked on a daily basis and if necessary drained.

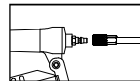

• For better performance, install a 3/8" quick connector (1/4" NPT threads) with an inside diameter of .315" on your tool and a 3/8" quick coupler on the air hose.

The following illustration shows the correct mode of connection to the air supply system which will increase the efficiency and useful life of the tool.

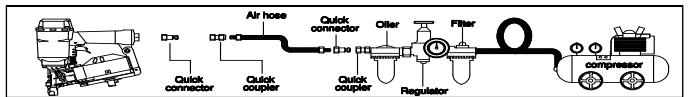

## LUBRICATION AND MAINTENANCE

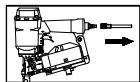

• Disconnect the air supply from the tool before lubricating.



• Your tool requires lubrication before you use it for the first time.

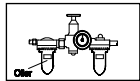

• Wipe off excessive oil at the exhaust. Excessive oil will damage O-rings of tool. If in-line oiler is used, manual lubrication through the air inlet is not required on a daily basis.

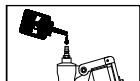

• Turn the tool so the inlet is facing up and put one drop of high speed spindle oil, UNOCAL RX22, or 3-IN-1 oil into air inlet. Never use detergent oil or additives. Operate the tool briefly after adding oil.

## LOADING THE TOOL

### **WARNING**

- Do not place your hand or any part of your body in the fastener discharge area of the tool when connecting or disconnecting air supply.

### **WARNING**

- Never point any operational fastener driving tool at yourself or at any other person.

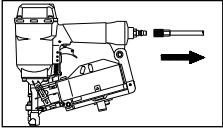

1. Disconnect air hose.

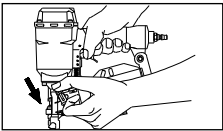

2. Press down on the feeder door latch and lift open feed door. Fold back magazine cover.

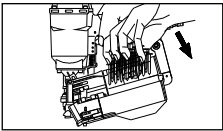

3. Place the nail coil in the magazine. Make sure nail tip face down and nails have no damages.

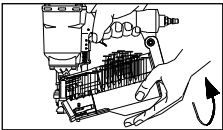

4. Close canister cover. And then close door. Make sure door latch is fully latched.

## OPERATING THE TOOL

### **WARNING**

Protect your eyes and ears. Wear z87.1 safety glasses with side shields. Wear hearing protection. Employers and users are responsible for ensuring the user or anyone near the tool wear this safety protection.



### **NOTE**

Check and replace any damaged or worn components on the tool. The safety warning labels on the tool must also be replaced if they are not legible.

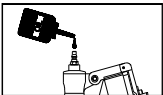

Fig.1

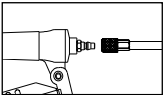

Fig.2

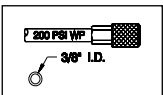

Fig.3

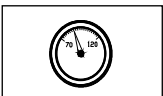

Fig.4

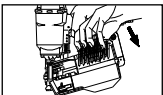

Fig.5

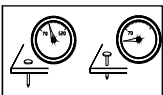
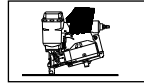

Fig.6

1. Add a few drops of UNOCAL RX22 or 3-in-1 oil into the air inlet. (See Fig. 1)
2. Attach a high flow quick connect fitting to the tool. (See Fig. 2)
3. Empty the magazine.
4. Connect the tool to an air compressor using a 3/8" I.D. hose. Make sure the hose has a rated working pressure exceeding 200 PSI (13.8bar) and a female quick coupler. (See Fig. 3)
5. Regulate the air pressure to obtain 70 PSI (4.8 bar) at the tool. (See Fig. 4)
6. Disconnect the air supply from the tool.
7. Load fasteners into your tool following the instructions in this manual. (See Fig. 5)
8. Reconnect the air supply to the tool.
9. Test for proper fastener penetration by driving nails into a sample piece of wood. If the fasteners do not achieve the desired penetration, adjust the air pressure to a higher setting until the desired penetration is achieved. Do not exceed 110 PSI (7.6 bar) at the tool. (See Fig. 6)

## CONTACT SAFETY TRIP MECHANISM

### OPERATING A CONTACT SAFETY TRIP TOOL :



- The operator requires finger to be off the trigger and the nose of the tool to be placed on the workpiece.

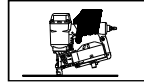

- The contact safety trip mechanism is then depressed against the workpiece and the trigger is pulled to drive a fastener.

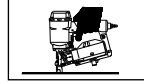

- The trigger is released after each fastener is driven.

- Move the tool to next location and the above procedure repeated.

### CHECKING OPERATION OF CONTACT SAFETY TRIP MECHANISM:

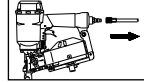

- Disconnect the air supply from the tool.



- Empty the magazine.

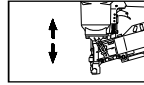

- Make sure the trigger and contact safety trip mechanism move up and down without any sticking.

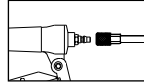

- Connect air supply to the tool.

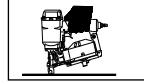

- Depress the contact safety trip mechanism against the workpiece without pulling the trigger. The tool must not cycle. Never use the tool if a cycle occurs.

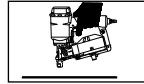

- Hold the tool clear of the workpiece. The contact safety trip mechanism should return to its original down position. Pull the trigger. The tool must not cycle. Never use the tool if a cycle occurs.

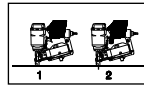

- Depress the contact safety mechanism again the workpiece and pull the trigger, the tool must cycle.

## CLEARING A JAM FROM THE TOOL

### **WARNING**

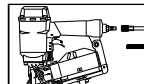

Disconnect the tool from air compressor before adjusting, clearing jams, servicing, relocating and during non-operation.

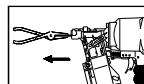

1. Fastener jammed in fastener discharge area:
  - Disconnect tool from air hose.
  - Grab jammed fastener with pliers and remove.

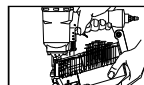

2. Fastener jam inside magazine:
  - Disconnect air tool from air hose.
  - Pull back on fastener pusher until locked.
  - Removed jammed fastener.
  - Release fastener pusher.

## CLEANING THE TOOL

### **DANGER**



Never use gasoline or other flammable liquids to clean the tool. Vapors in the tool will ignite by a spark and cause the tool to explode and result in death or serious personal injury.

### **NOTE**

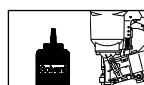

Solvents used to clean the nose of the tool and contact safety trip mechanism may soften the tar on the shingles and cause the buildup to be accelerated. Make sure to dry the tool thoroughly after cleaning and before operating the tool again.

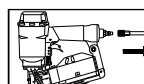

1. Disconnect the air supply from the tool.

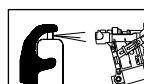

2. Remove tar buildup with kerosene #2 fuel oil or diesel fuel. Do not allow solvent to get into the cylinder or damage may occur. Dry off the tool completely before use.

# R45B10 (CC/S1-10)

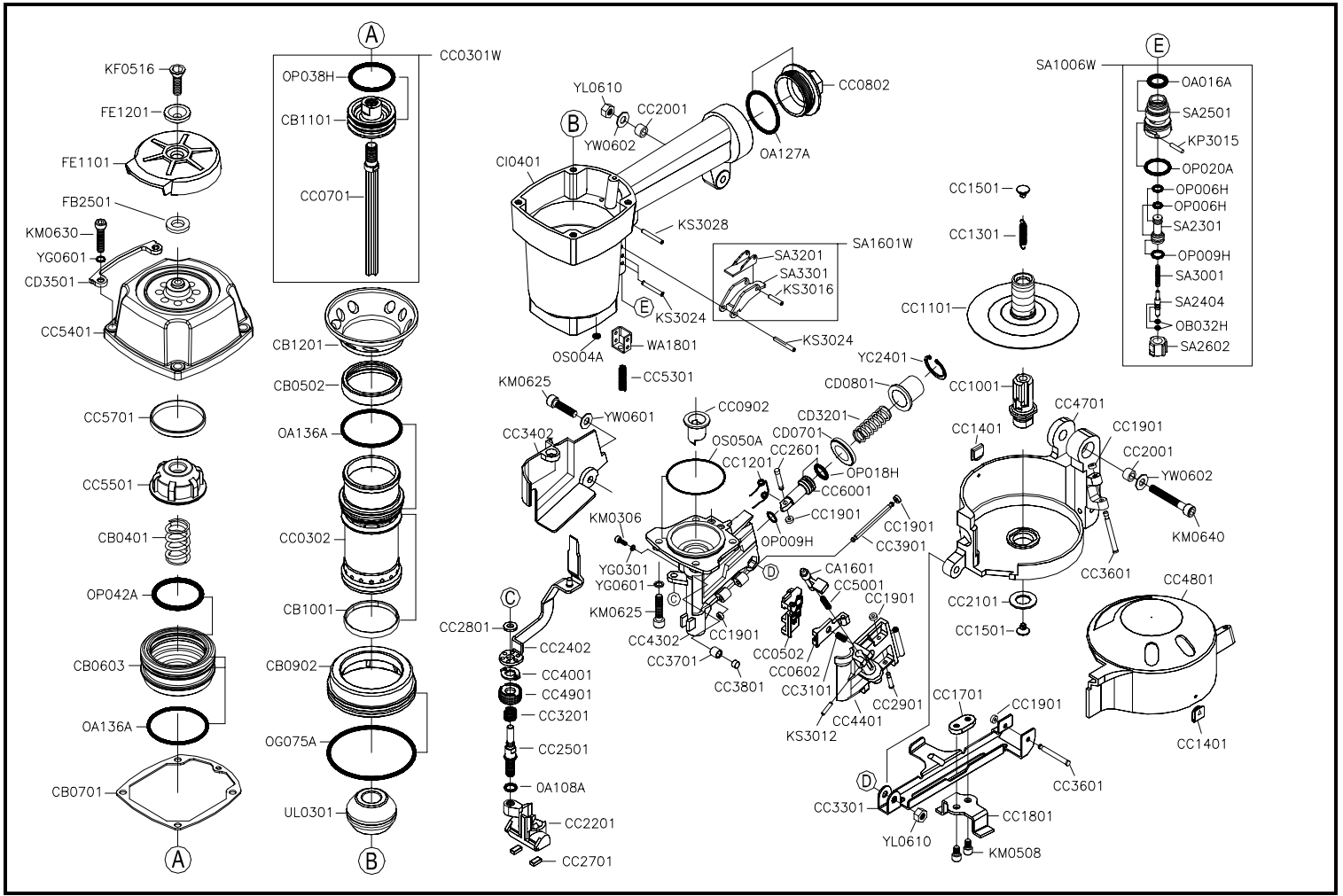

Part_No	Description	Spec	Q'ty	Part_No	Description	Spec	Q'ty	Part_No	Description	Spec	Q'ty
CA1601	DOOR LATCH		1	CC3201	COMPRESSION SPRING		1	KS3016	SPRING PIN	§ 3-16L	1
CB0401	COMPRESSION SPRING		1	CC3301	GAGE BRACKET		1	KS3024	SPRING PIN	§ 3-24L	3
CB0502	CYLINDER RING		1	CC3402	TRIP COVER		1	KS3028	SPRING PIN	§ 3-28L	1
CB0603	HEAD VALVE PISTON		1	CC3601	PIN		2	OA016A	O-RING	ARP568-016	1
CB0701	CAP SEAL		1	CC3701	SEAT		1	OA108A	O-RING	ARP568-108	1
CB0902	CYLINDER RING		1	CC3801	STEEL		1	OA127A	O-RING	ARP568-127	1
CB1001	CHECK SEAL		1	CC3901	PIN		1	OA136A	O-RING	ARP568-136	3
CB1101	MAIN PISTON		1	CC4001	FIXED SEAT		1	OB032H	O-RING	2.5x1.4	2
CB1201	COLLAR		1	CC4302	NOSE		1	OG075A	O-RING	G75	1
CC0301W	DRIVER ASSY.		1	CC4401	DOOR		1	OP006H	O-RING	5.8x1.9	2
CC0302	CYLINDER		1	CC4701	CANISTER		1	OP009H	O-RING	8.8x1.9	2
CC0502	FEED PAWL		1	CC4801	CANISTER COVER		1	OP018H	O-RING	17.8x2.4	1
CC0602	HOLDING PAWL		1	CC4901	ADJUSTING WHEEL		1	OP020A	O-RING	P20	1
CC0701	DRIVER		1	CC5001	COMPRESSION SPRING		1	OP038H	O-RING	37.7x3.5	1
CC0802	END CAP		1	CC5301	COMPRESSION SPRING		1	OP042A	O-RING	P42	1
CC0902	DRIVER GUIDE		1	CC5401	CYLINDER CAP		1	OS004A	O-RING	S-4	1
CC1001	MAGAZINE POST		1	CC5501	PISTON STOP		1	OS050A	O-RING	S-50	1
CC1101	PLATFORM ASSY.		1	CC5701	SPACER		1	SA1006W	RESTRICTIVE TRIGGER ASSY		1
CC1201	SPRING		1	CC6001	FEED PISTON CAP		1	SA1601W	TRIGGER ASSY.		1
CC1301	PULL SPRING		1	CD0701	PISTON BUMPER		1	SA2301	PILOT VALVE		1
CC1401	WEAR CLIP		2	CD0801	FEED PISTON CAP		1	SA2404	TRIGGER VALVE STEM		1
CC1501	SPRING RECEIVER		2	CD3201	COMPRESSION SPRING		1	SA2501	TRIGGER VALVE SEAT		1
CC1701	NUT PLATE		2	CD3501	WEAR PLATE		2	SA2602	TRIGGER VALVE SEAT		1
CC1801	GAGE		1	CI0401	BODY		1	SA3001	COMPRESSION SPRING		1
CC1901	BUSHING		6	FB2501	PISTON STOP		1	SA3201	CONTACT LEVER		1
CC2001	BUSHING		2	FE1101	EXHAUST CAP		1	SA3301	TRIGGER		1
CC2101	RETAINER POST		1	FE1201	EXHAUST CAP RING		1	UL0301	BUMPER		1
CC2201	TRIP FOOT		1	KF0516	FLAT HD.BOLT	M5x0.8 - 16L	1	WA1801	SAFETY GUIDE		1
CC2402	SAFETY		1	KM0306	HEX.SOC.HD.BOLT	M3x0.5 - 6L	1	YC2401	C-RING	§ 24	1
CC2501	ADJUSTING PIN		1	KM0508	HEX.SOC.HD.BOLT	M5x0.8 - 8L	2	YG0301	SPRING WASHER	§ 3	1
CC2601	PIN		1	KM0625	HEX.SOC.HD.BOLT	M6x1.0 - 25L	5	YG0601	SPRING WASHER	§ 6	8
CC2701	BLOCK		2	KM0630	HEX.SOC.HD.BOLT	M6x1.0 - 30L	4	YL0610	LOCK NUT	M6x1.0	2
CC2801	BUSHING		1	KM0640	HEX.SOC.HD.BOLT	M6x1.0 - 40L	1	YW0601	FLAT WASHER	§ 6	1
CC2901	PIN		1	KP3015	PARALLEL PIN	§ 3x15L	2	YW0602	FLAT WASHER	§ 6	2
CC3101	COMPRESSION SPRING		1	KS3012	SPRING PIN	§ 3-12L	1				

★☆☆ If you need to order parts, please mark both Parts No. and Description. ★☆☆