

OPERATING INSTRUCTIONS AND PARTS MANUAL

MODEL S-90D

Framing Nailer

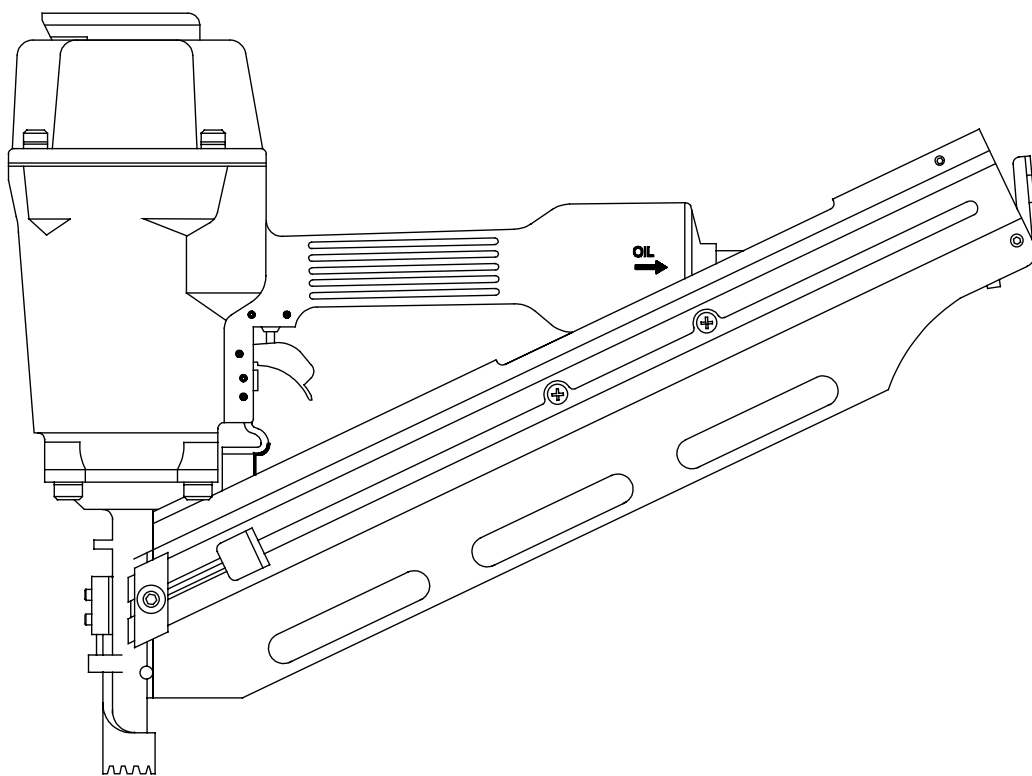

CAREFULLY READ THIS MANUAL BEFORE OPERATING TOOL

APLUS Pneumatic Corp.
NO.579, SEC. 1, SHEN LIN RD., TAYA,TAICHUNG CITY 428 TAIWAN, R.O.C.
Tel: 886-4-25602860 Fax: 886-4-25602859
Original instructions

OPERATING INSTRUCTIONS AND PARTS MANUAL

MODEL S-90D

Framing Nailer

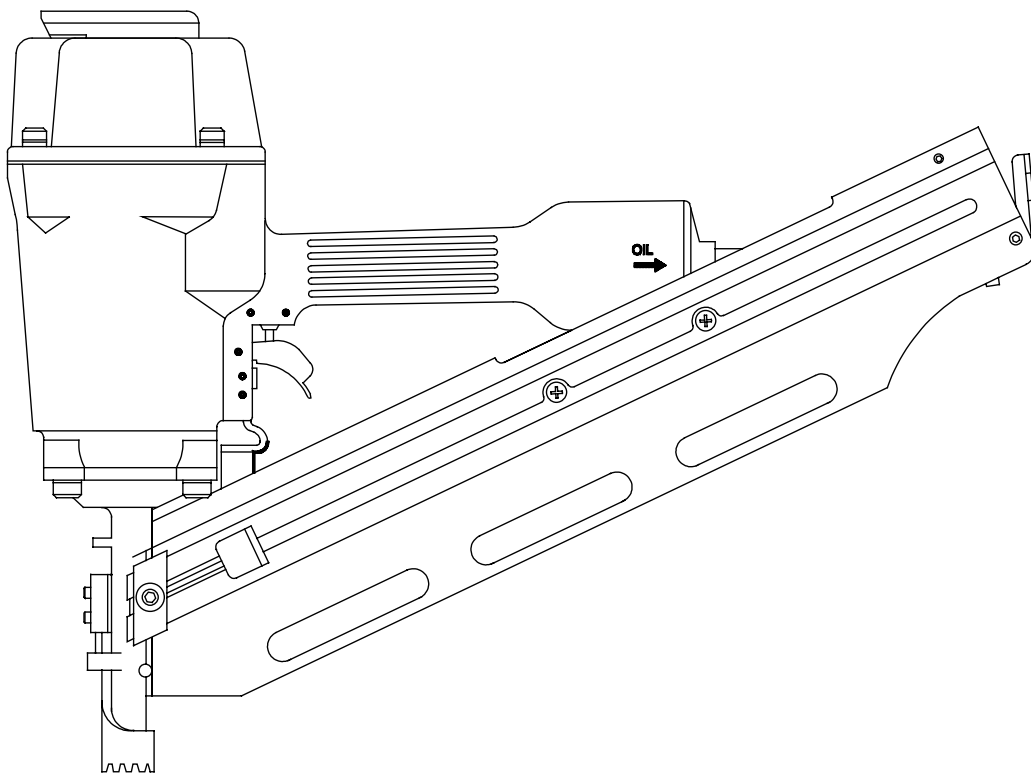

CAREFULLY READ THIS MANUAL BEFORE OPERATING TOOL

TOOL SPECIFICATIONS

MODEL OF TOOL	S-90D
TOOL LENGTH	21.46" (545 mm)
TOOL HEIGHT	14.17" (360 mm)
TOOL WIDTH	5.00" (127 mm)
WEIGHT (WITHOUT FASTENERS)	8.16 lbs (3.7 kg)
AIR INLET	1/4" NPT

COMPRESSED AIR :

Maximum permissible operating pressure	115 PSIG (8 bar)
Recommended operating pressure range	75 110 PSIG (5 7.5 bar)
AIR CONSUMPTION.....	2.342 scfm with 25 nails per minute @ 90 psi (6.2 bar)

Noise dB(A) :

A-weighted sound pressure level LpA..... 87.21 dB(A)

A-weighted sound power level LwA..... 100.21 dB(A)

Measurement uncertainty: 3dB

Vibration (m/s²) :

Hand-arm vibration value..... 5.43 m/s²

Measurement uncertainty: 1.5 m/s²

Warning:

The vibration emission during actual use of the power tool can differ from the declared total value depending on the ways in which the tool is used; and of the need to identify safety measures to protect the operator that are based on an estimation of exposure in the actual conditions of use (taking account of all parts of the operation cycle such as the times when the tool is switched off and when it is running idle in addition to the trigger time).

List of fasteners for S-90D :

Shank Dia.				MAGAZINE
2.9	4.2 mm	0.11	0.17 "	56 70 pcs

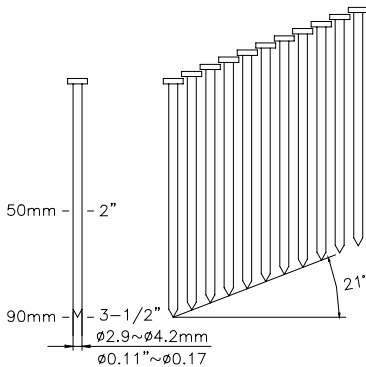

Foreword:

This pneumatic framing nailer is designed for truss building, blocking, pallet making and crate and box assembling. Its well balanced, ergonomic, comfort non-slip cushioned grip and heavy duty driving compatible staples to proper applications ensure you a satisfactory tackle and enjoy work. Rigid depth of drive adjustment is to adjust nailing penetration.

Suitable applications:

Truss building, blocking, pallet making and crate and box assembling.

Caution:

Framing nailers are only applying on wood. Not suitable for stapling or nailing into concrete, masonry bricks or steel. Do not fire if staples are jammed, as this will cause damage to the relevant parts.



Indicates an imminently hazardous situation which, if not avoided, will result in death or serious injury.

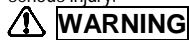

Indicates a potentially hazardous situation which, if not avoided, will result in death or serious injury.



Alerts the operator to useful information.

SAFETY INSTRUCTIONS



1. Read this manual and understand all safety instructions before operation the tool. If you have any questions, please contact our authorized representatives.
2. Only those fasteners listed in the operating instructions may be used in the fastener driving tools.
3. Only the main energy and the lubricants listed in the operating instructions may be used.
4. Fastener driving tools marked with an inverted equilateral triangle standing on one point may only be used with an effective safety yoke.
5. Fastener driving tools equipped with contact actuation or continuous contact actuation, marked with the symbol " Do not use on scaffoldings, ladders", shall not be used for specific application for example: when changing one driving location to another involves the use of scaffoldings, stairs, ladders, or ladder alike constructions, e.g. roof laths, closing boxes or crates, fitting transportation safety systems e.g. on vehicles and wagons.
6. For the maintenance of fastener driving tools, only spare parts specified by the manufacturer or his authorized representative shall be used.
7. Repairs shall carried out by agents authorized by the manufacturer or by other specialis-

ts, having due regard to the information given in the operating instruction.

8. Stands for mounting the fastener driving tools to a support for example a work table shall be designed and constructed by the stand manufacturer in such a way that the fastener driving tool can be safely fixed for the intended use, thus for example avoiding damage, distortion or displacement.
9. Fastener driving tools operated by compressed air shall only be connected to compressed air lines where the maximum allowable pressure cannot be exceed by a factor of more than 10%, which can for example be achieved by a pressure reduction valve which includes a downstream safety valve.
10. When using fastener driving tools operated by compressed air, particular attention must be paid to avoid exceeding the maximum allowable pressure.
11. When using fastener driving tools operated by compressed air should only be operated at the lowest pressure required for the work process at hand, in order to prevent unnecessarily high noise levels, increased wear and resulting failures.
12. Hazards caused by fire and explosion when using oxygen or combustible gases for operating compressed air operated fastener driving tools.
13. Carry the fastener driving tool at workpiece using only the handgrip, and never with the trigger actuated. Never carry the tool by the hose or pull the hose to move the tool.

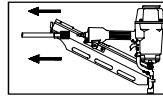

14. Disconnect the tool from air supply before cleaning jams, servicing, adjusting, and during non-operation.



15. Wear eye protection.

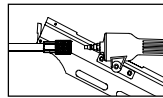

16. Do not use a check valve or any other fitting which allows air to remain in the tool.



17. Do not place your hand or any part of your body in the fastener discharge area of the tool when connecting or disconnecting air supply.



18. Never point tool at yourself or at any other person.



19. Do not use on scaffoldings, ladders.

AIR SUPPLY AND CONNECTION



Many air tool users find it convenient to use oiler to help provide oil circulation through tool and increase the efficiency and useful life of the tool. Check oil level in the oiler daily.

Many air tool user find it convenient to use a filter to remove liquid and impurities which can rust or wear internal parts of the tool. A filter also increase the efficiency and useful of the tool. The filter must be checked on a daily basis and if necessary drained.

For better performance, install a 3/8" quick connector (1/4" NPT threads) with an inside diameter of .315" on your tool and a 3/8" quick coupler on the air hose.

The following illustration shows the correct mode of connection to the air supply system which will increase the efficiency and useful life of the tool.

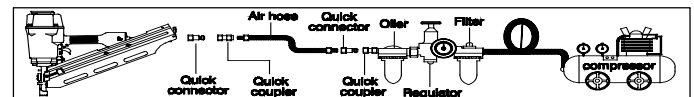

LUBRICATION AND MAINTENANCE



Disconnect the air supply from the tool before lubricating.

Your tool requires lubrication before you use it for the first time.

Wipe off excessive oil at the exhaust. Excessive oil will damage O-rings of tool. If in-line oiler is used, manual lubrication through the air inlet is not required on a daily basis.

Turn the tool so the inlet is facing up and put one drop of high speed spindle oil, UNOCAL RX22, or 3-IN-1 oil into air inlet. Never use detergent oil or additives. Operate the tool briefly after adding oil.

LOADING THE TOOL

WARNING

Do not place your hand or any part of your body in the fastener discharge area of the tool when connecting or disconnecting air supply.

WARNING

Never point any operational fastener driving tool at yourself or at any other person.

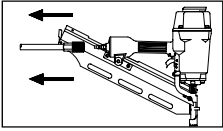

1. Disconnect air hose.

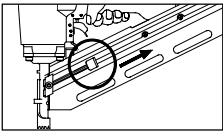

2. Pull the pusher back until the latch latches it.

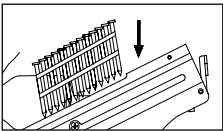

3. Insert a stick of fasteners into the magazine. Make sure the pointed ends of the fasteners are loaded with the points downward. Also make sure fasteners are not dirty or damaged.

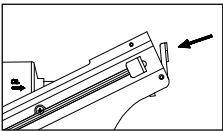

4. Slightly pull back the pusher and push the latch to release the pusher. And carefully allow the pusher to slide forward until it makes contact with the rearmost nail stick.

OPERATING THE TOOL

WARNING

Protect your eyes and ears. Wear z87.1 safety glasses with side shields. Wear hearing protection. Employers and users are responsible for ensuring the user or anyone near the tool wear this safety protection.



NOTE

Check and replace any damaged or worn components on the tool. The safety warning labels on the tool must also be replaced if they are not legible.

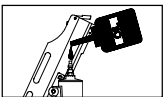

Fig.1

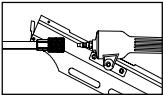

Fig.2

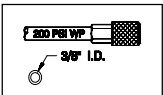

Fig.3



Fig.4

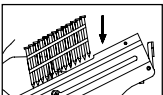

Fig.5

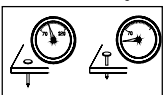
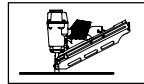

Fig.6

1. Add a few drops of UNOCAL RX22 or 3-in-1 oil into the air inlet. (See Fig. 1)
2. Attach a high flow quick connect fitting to the tool. (See Fig. 2)
3. Empty the magazine.
4. Connect the tool to an air compressor using a 3/8" I.D. hose. Make sure the hose has a rated working pressure exceeding 200 PSI (13.8bar) and a female quick coupler. (See Fig. 3)
5. Regulate the air pressure to obtain 70 PSI (4.8 bar) at the tool. (See Fig. 4)
6. Disconnect the air supply from the tool.
7. Load fasteners into your tool following the instructions in this manual. (See Fig. 5)
8. Reconnect the air supply to the tool.
9. Test for proper fastener penetration by driving nails into a sample piece of wood. If the fasteners do not achieve the desired penetration, adjust the air pressure to a higher setting until the desired penetration is achieved. Do not exceed 110 PSI (7.6 bar) at the tool. (See Fig. 6)

CONTACT SAFETY TRIP MECHANISM

OPERATING A CONTACT SAFETY TRIP TOOL :



- The operator requires finger to be off the trigger and the nose of the tool to be placed on the workpiece.

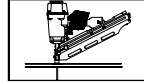

- The contact safety trip mechanism is then depressed against the workpiece and the trigger is pulled to drive a fastener.

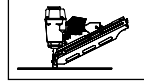

- The trigger is released after each fastener is driven.

- Move the tool to next location and the above procedure repeated.

CHECKING OPERATION OF CONTACT SAFETY TRIP MECHANISM:

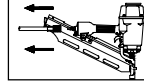

- Disconnect the air supply from the tool.

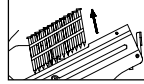

- Empty the magazine.

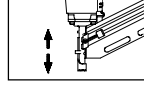

- Make sure the trigger and contact safety trip mechanism move up and down without any sticking.

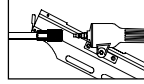

- Connect air supply to the tool.

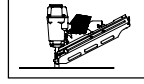

- Depress the contact safety trip mechanism against the workpiece without pulling the trigger. The tool must not cycle. Never use the tool if a cycle occurs.

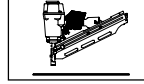

- Hold the tool clear of the workpiece. The contact safety trip mechanism should return to its original down position. Pull the trigger. The tool must not cycle. Never use the tool if a cycle occurs.

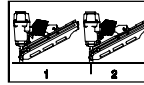

- Depress the contact safety mechanism again the workpiece and pull the trigger, the tool must cycle.

CLEARING A JAM FROM THE TOOL

WARNING

Disconnect the tool from air compressor before adjusting, clearing jams, servicing, relocating and during non-operation.

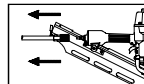

1. Fastener jammed in fastener discharge area: Disconnect tool from air hose.

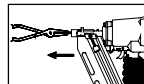

Grab jammed fastener with pliers and remove.

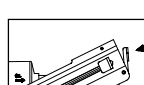

2. Fastener jam inside magazine:

Disconnect air tool from air hose.

Pull back on fastener pusher until locked.

Removed jammed fastener.

Release fastener pusher.

CLEANING THE TOOL

DANGER



Never use gasoline or other flammable liquids to clean the tool. Vapors in the tool will ignite by a spark and cause the tool to explode and result in death or serious personal injury.

NOTE



Solvents used to clean the nose of the tool and contact safety trip mechanism may soften the tar on the shingles and cause the buildup to be accelerated. Make sure to dry the tool thoroughly after cleaning and before operating the tool again.

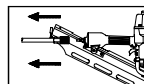

1. Disconnect the air supply from the tool.

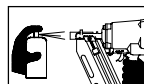

2. Remove tar buildup with kerosene #2 fuel oil or diesel fuel. Do not allow solvent to get into the cylinder or damage may occur. Dry off the tool completely before use.

S90DB08 (SD/S1-08)

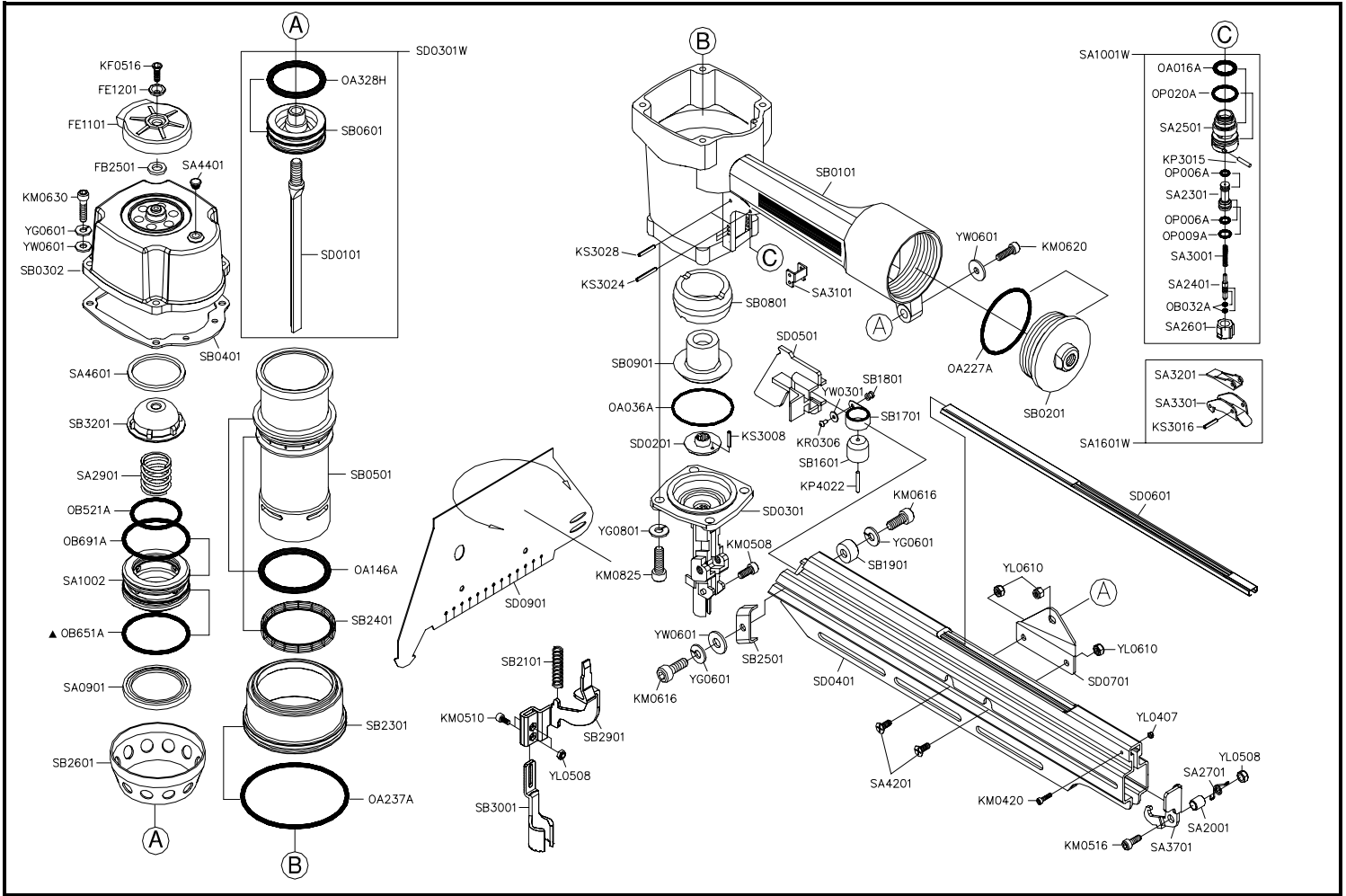

Part_No	Description	Spec	Q'ty	Part_No	Description	Spec	Q'ty	Part_No	Description	Spec	Q'ty
FB2501	PISTON STOP		1	OP009A	O-RING	P9	1	SB1701	PUSHER SPRING		1
FE1101	EXHAUST CAP		1	OP020A	O-RING	P20	1	SB1801	SPRING SEAT		1
FE1201	EXHAUST CAP RING		1	SA0901	HEAD VALVE SEAL		1	SB1901	WASHER		1
KF0516	FLAT HD.BOLT	M5×0.8 - 16L	1	SA1001W	RESTRICTIVE TRIGGER ASSY.		1	SB2101	COMPRESSION SPRING		1
KM0420	HEX.SOC.HD.BOLT	M4×0.7 - 20L	1	SA1002	HEAD VALVE PISTON		1	SB2301	CYLINDER RING		1
KM0508	HEX.SOC.HD.BOLT	M5×0.8 - 8L	2	SA1601W	TRIGGER ASSY.		1	SB2401	CHECK SEAL		1
KM0510	HEX.SOC.HD.BOLT	M5×0.8 - 10L	2	SA2001	LATCH BUSHING		1	SB2501	SUPPORT		1
KM0516	HEX.SOC.HD.BOLT	M5×0.8 - 16L	1	SA2301	PILOT VALVE		1	SB2601	COLLAR		1
KM0616	HEX.SOC.HD.BOLT	M6×1.0 - 16L	2	SA2401	TRIGGER VALVE STEM		1	SB2901	SAFETY		1
KM0620	HEX.SOC.HD.BOLT	M6×1.0 - 20L	1	SA2501	TRIGGER VALVE SEAT		1	SB3001	WORK CONTACTING ELEMENT		1
KM0630	HEX.SOC.HD.BOLT	M6×1.0 - 30L	4	SA2601	TRIGGER VALVE SEAT		1	SB3201	PISTON STOP		1
KM0825	HEX.SOC.HD.BOLT	M8×1.25 - 25L	4	SA2701	SPRING		1	SD0101	DRIVER		1
KP3015	PARALLEL PIN	3×15L	2	SA2901	COMPRESSION SPRING		1	SD0201	DRIVER GUIDE		1
KP4022	PARALLEL PIN	4×22L	1	SA3001	COMPRESSION SPRING		1	SD0301	NOSE		1
KR0306	BUTTON HD.BOLT	M3×0.5 - 6L	1	SA3101	SAFETY GUIDE		1	SD0301W	DRIVER ASSY.		1
KS3008	SPRING PIN	3-8L	1	SA3201	CONTACT LEVER		1	SD0401	MAGAZINE SEAT		1
KS3016	SPRING PIN	3-16L	1	SA3301	TRIGGER		1	SD0501	PUSHER		1
KS3024	SPRING PIN	3-24L	3	SA3701	LATCH		1	SD0601	NAIL GUIDE		1
KS3028	SPRING PIN	3-28L	2	SA4201	SCREW		2	SD0701	SUPPORT		1
OA016A	O-RING	ARP568-016	1	SA4401	GROMMET		1	SD0901	DUST SHIELD		1
OA036A	O-RING	ARP568-036	1	SA4601	SPACER		1	YG0601	SPRING WASHER	6	6
OA146A	O-RING	ARP568-146	1	SB0101	BODY		1	YG0801	SPRING WASHER	8	4
OA227A	O-RING	ARP568-227	1	SB0201	END CAP		1	YL0407	LOCK NUT	M4×0.7	1
OA237A	O-RING	ARP568-237	1	SB0302	CYLINDER CAP		1	YL0508	LOCK NUT	M5×0.8	3
OA328H	O-RING	46.99×5.33	1	SB0401	CAP SEAL		1	YL0610	LOCK NUT	M6×1.0	3
OB032A	O-RING	2.5×1.4	2	SB0501	CYLINDER		1	YW0301	FLAT WASHER	3	1
OB521A	O-RING	51.5×3.1	1	SB0601	MAIN PISTON		1	YW0601	FLAT WASHER	6	6
▲ OB651A	O-RING	65×3	1	SB0801	TOP BUMPER		1				
▲ OB691A	O-RING	68.5×2.95	1	SB0901	BOTTOM BUMPER		1				
OP006A	O-RING	P6	2	SB1601	ROLLER		1				

If you need to order parts, please mark both Parts No. and Description.