

OPERATING INSTRUCTIONS AND PARTS MANUAL

MODEL SP88/25SJ

Air Plier

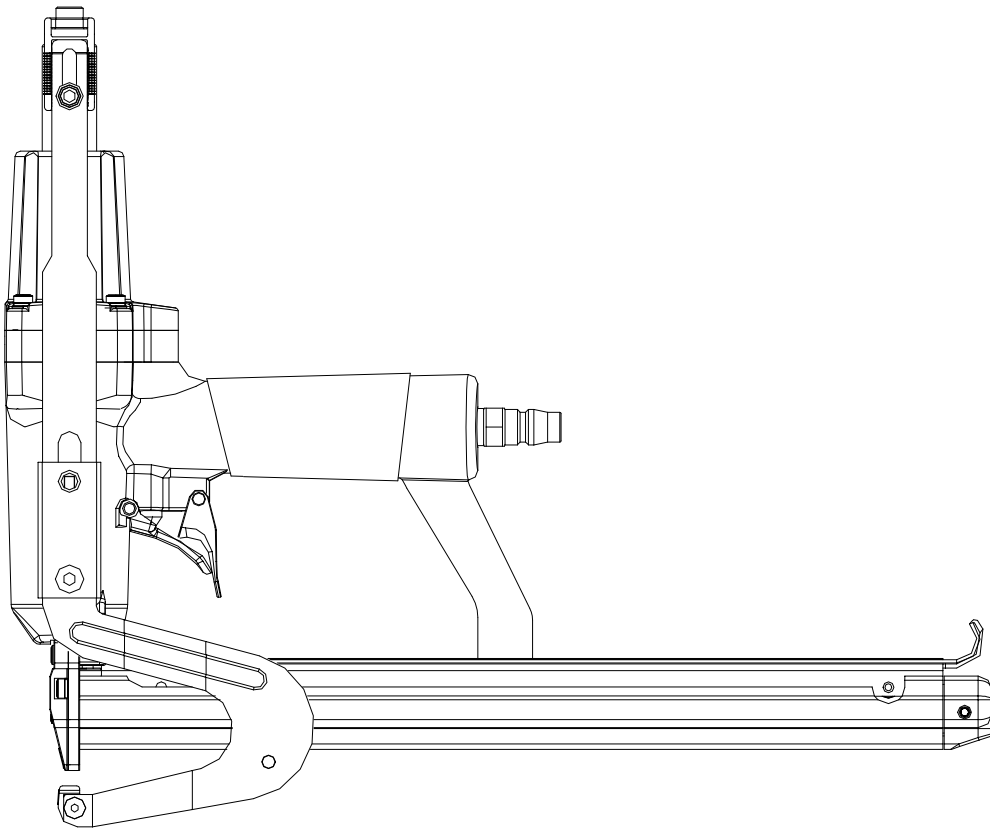

CAREFULLY READ THIS MANUAL BEFORE OPERATING TOOL

APLUS Pneumatic Corp.
NO.579, SEC. 1, SHEN LIN RD., TAYA, TAICHUNG CITY 428 TAIWAN, R.O.C.
Tel: 886-4-25602860 Fax: 886-4-25602859
Original instructions

OPERATING INSTRUCTIONS AND PARTS MANUAL

MODEL SP88/25SJ

Air Plier

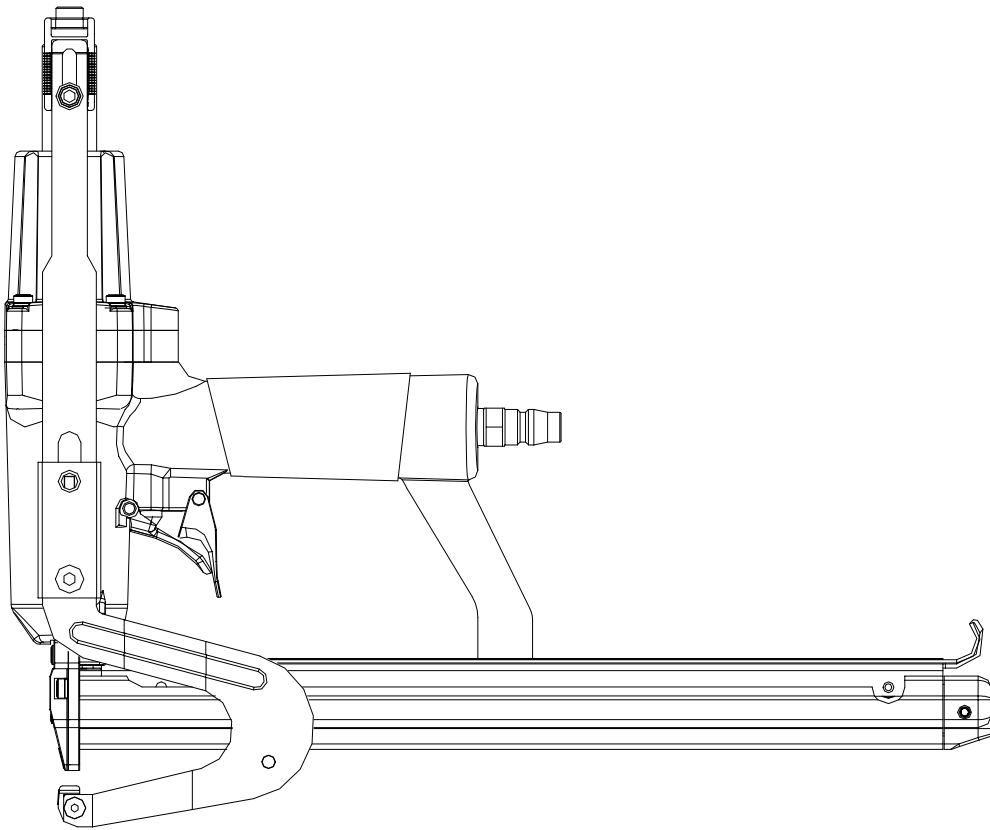

CAREFULLY READ THIS MANUAL BEFORE OPERATING TOOL

TOOL SPECIFICATIONS

MODEL OF TOOL	SP88/25SJ
TOOL LENGTH	14.25" (362 mm)
TOOL HEIGHT	11.89" (302 mm)
TOOL WIDTH	2.83" (72 mm)
WEIGHT (WITHOUT FASTENERS)	4.63 lbs (2.1 kg)
AIR INLET	1/4" NPT
COMPRESSED AIR :	
Maximum permissible operating pressure	110 PSIG (7.5 bar)
Recommended operating pressure range	75 ~ 100 PSIG (5 ~ 7 bar)
AIR CONSUMPTION.....	0.0046 scfm with 25 nails per minute @ 100 psi (6.9 bar)

Noise dB(A) :	
A-weighted sound pressure level LpA.....	82.29 dB(A)
A-weighted sound power level LwA.....	95.29 dB(A)
Measurement uncertainty: 3dB	
Vibration (m/s²) :	
Hand-arm vibration value.....	3.33 m/s ²
Measurement uncertainty: 1.5 m/s ²	

Warning:

The vibration emission during actual use of the power tool can differ from the declared total value depending on the ways in which the tool is used; and of the need to identify safety measures to protect the operator that are based on an estimation of exposure in the actual conditions of use (taking account of all parts of the operation cycle such as the times when the tool is switched off and when it is running idle in addition to the trigger time).

List of fasteners for SP88/25SJ :

Crown	Thickness	Width	MAGAZINE
13.2 mm 0.52 "	0.5 mm 0.02 "	1.2 mm 0.047 "	200 pcs

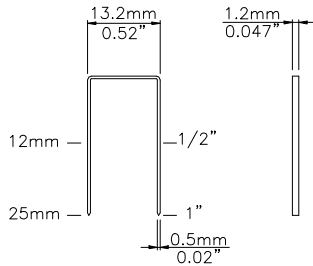

Foreword:

This pneumatic plier is designed for driving staples U to fix mattress padding. Connecting pads, sisal or foam to innerspring. Its well balanced, ergonomic and comfort non-slip cushioned grip ensure you a satisfactory tackle and enjoy work.

Suitable applications:

Bedding industry, mattresses assembly, fastening of foam-rubber.

Caution:

Pliers are ideal for mattresses padding. Not suitable for stapling or nailing into concrete, masonry bricks or steel. Do not fire if nails are jammed, as this will cause damage to the C-ring tool.



Indicates an imminently hazardous situation which, if not avoided, will result in death or serious injury.

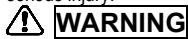

Indicates a potentially hazardous situation which, if not avoided, will result in death or serious injury.

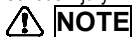

Alerts the operator to useful information.

SAFETY INSTRUCTIONS



1. Read this manual and understand all safety instructions before operation the tool. If you have any questions, please contact our authorized representatives.
2. Only those fasteners listed in the operating instructions may be used in the fastener driving tools.
3. Only the main energy and the lubricants listed in the operating instructions may be used.
4. Fastener driving tools equipped with contact actuation or continuous contact actuation, marked with the symbol " Do not use on scaffoldings, ladders", shall not be used for specific application for example:
 - when changing one driving location to another involves the use of scaffoldings, stairs, ladders, or ladder alike constructions, e.g. roof laths,
 - closing boxes or crates,
 - fitting transportation safety systems e.g. on vehicles and wagons.
5. For the maintenance of fastener driving tools, only spare parts specified by the manufac-

turer or his authorized representative shall be used.

6. Repairs shall carried out by agents authorized by the manufacturer or by other specialists, having due regard to the information given in the operating instruction.
7. Stands for mounting the fastener driving tools to a support for example a work table shall be designed and constructed by the stand manufacturer in such a way that the fastener driving tool can be safely fixed for the intended use, thus for example avoiding damage, distortion or displacement.
8. Fastener driving tools operated by compressed air shall only be connected to compressed air lines where the maximum allowable pressure cannot be exceed by a factor of more than 10%, which can for example be achieved by a pressure reduction valve which includes a downstream safety valve.
9. When using fastener driving tools operated by compressed air, particular attention must be paid to avoid exceeding the maximum allowable pressure.
10. When using fastener driving tools operated by compressed air should only be operated at the lowest pressure required for the work process at hand, in order to prevent unnecessarily high noise levels, increased wear and resulting failures.
11. Hazards caused by fire and explosion when using oxygen or combustible gases for operating compressed air operated fastener driving tools.
12. Carry the fastener driving tool at workpiece using only the handgrip, and never with the trigger actuated. Never carry the tool by the hose or pull the hose to move the tool.

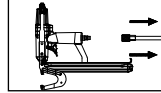

13. Disconnect the tool from air supply before cleaning jams, servicing, adjusting, and during non-operation.



14. Wear eye protection.

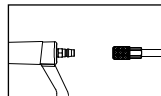

15. Do not use a check valve or any other fitting which allows air to remain in the tool.



16. Do not place your hand or any part of your body in the fastener discharge area of the tool when connecting or disconnecting air supply.



17. Never point tool at yourself or at any other person.

AIR SUPPLY AND CONNECTION

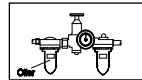

- Many air tool users find it convenient to use oiler to help provide oil circulation through tool and increase the efficiency and useful life of the tool. Check oil level in the oiler daily.

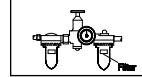

- Many air tool user find it convenient to use a filter to remove liquid and impurities which can rust or wear internal parts of the tool. A filter also increase the efficiency and useful of the tool. The filter must be checked on a daily basis and if necessary drained.

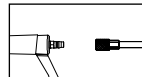

- For better performance, install a 3/8" quick connector (1/4" NPT threads) with an inside diameter of .315" on your tool and a 3/8" quick coupler on the air hose.

The following illustration shows the correct mode of connection to the air supply system which will increase the efficiency and useful life of the tool.

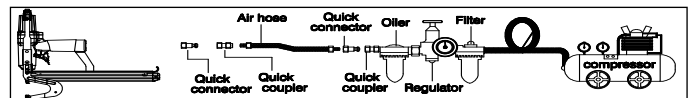

LUBRICATION AND MAINTENANCE

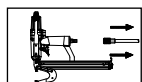

- Disconnect the air supply from the tool before lubricating.

- Your tool requires lubrication before you use it for the first time.

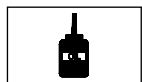

- Wipe off excessive oil at the exhaust. Excessive oil will damage O-rings of tool. If in-line oiler is used, manual lubrication through the air inlet is not required on a daily basis.

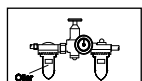

- Turn the tool so the inlet is facing up and put one drop of high speed spindle oil, UNOCAL RX22, or 3-IN-1 oil into air inlet. Never use detergent oil or additives. Operate the tool briefly after adding oil.



LOADING THE TOOL

⚠ WARNING

- Do not place your hand or any part of your body in the fastener discharge area of the tool when connecting or disconnecting air supply.

⚠ WARNING

- Never point any operational fastener driving tool at yourself or at any other person.

1. Disconnect air hose.

2. Pull back on the magazine cover.

3. Insert a stick of fasteners into the magazine. Make sure the pointed ends of the fasteners are loaded with the points downward. Also make sure fasteners are not dirty or damaged.

4. Push the magazine cover forward until the latch catches.

OPERATING THE TOOL

⚠ WARNING

Protect your eyes and ears. Wear z87.1 safety glasses with side shields. Wear hearing protection. Employers and users are responsible for ensuring the user or anyone near the tool wear this safety protection.

⚠ NOTE

Check and replace any damaged or worn components on the tool. The safety warning labels on the tool must also be replaced if they are not legible.

1. Add a few drops of UNOCAL RX22 or 3-in-1 oil into the air inlet. (See Fig. 1)
2. Attach a high flow quick connect fitting to the tool. (See Fig. 2)
3. Empty the magazine.
4. Connect the tool to an air compressor using a 3/8" I.D hose. Make sure the hose has a rated working pressure exceeding 200 PSI (13.8bar) and a female quick coupler. (See Fig. 3)
5. Regulate the air pressure to obtain 70 PSI (4.8 bar) at the tool. (See Fig. 4)
6. Disconnect the air supply from the tool.
7. Load fasteners into your tool following the instructions in this manual. (See Fig. 5)
8. Reconnect the air supply to the tool.
9. Test for proper fastener penetration by driving nails into a sample piece of wood. If the fasteners do not achieve the desired penetration, adjust the air pressure to a higher setting until the desired penetration is achieved. Do not exceed 110 PSI (7.6 bar) at the tool. (See Fig. 6)

CLEARING A JAM FROM THE TOOL

⚠ WARNING

Disconnect the tool from air compressor before adjusting, clearing jams, servicing, relocating and during non-operation.

1. Fastener jammed in fastener discharge area:
 - Disconnect tool from air hose.
 - Grab jammed fastener with pliers and remove.
2. Fastener jam inside magazine:
 - Disconnect air tool from air hose.
 - Pull back on fastener pusher until locked.
 - Removed jammed fastener.
 - Release fastener pusher.

CLEANING THE TOOL

⚠ DANGER

Never use gasoline or other flammable liquids to clean the tool. Vapors in the tool will ignite by a spark and cause the tool to explode and result in death or serious personal injury.

⚠ NOTE

Solvents used to clean the nose of the tool and contact safety trip mechanism may soften the tar on the shingles and cause the buildup to be accelerated. Make sure to dry the tool thoroughly after cleaning and before operating the tool again.

1. Disconnect the air supply from the tool.

2. Remove tar buildup with kerosene #2 fuel oil or diesel fuel. Do not allow solvent to get into the cylinder or damage may occur. Dry off the tool completely before use.

TROUBLESHOOTING

Stop using the tool immediately if any of the following problems occur. Serious personal injury could. Any repairs or replacements must be done by a qualified person or an authorized service center only.

PROBLEM	CAUSES	REMEDIES
Serious air leaking from valve holes	Lower O-ring and trigger valve worn out or not in position. O-ring plug of piston rod O-ring valves worn out Plug loose	Replace Replace Replace Tighten
Air leaking from hole under cylinder bridge	O-ring piston worn out	Replace
Does not drive staple but jaw closes	Small valve dirty Exhaust pinhole plunger or too tight Insufficient lubrication	Lubricate Clean pinhole and outer diaphragm Lubricate
Air leaking from valve holes	O-ring piston valve not completely closed	Replace inner piston valve O-ring and lubricate.
Staples are not completely closed	Jaw fall block is bent or damaged	Replace block
Jaw does not return	Bridge is not squared up	Square up
Slow operations	Lack of lubrication	Lubricate
Staples jam	Driver worn out De-jamming block springs slack.	Replace Replace

SP88/25SJLA01 (WU/A1-01)

k

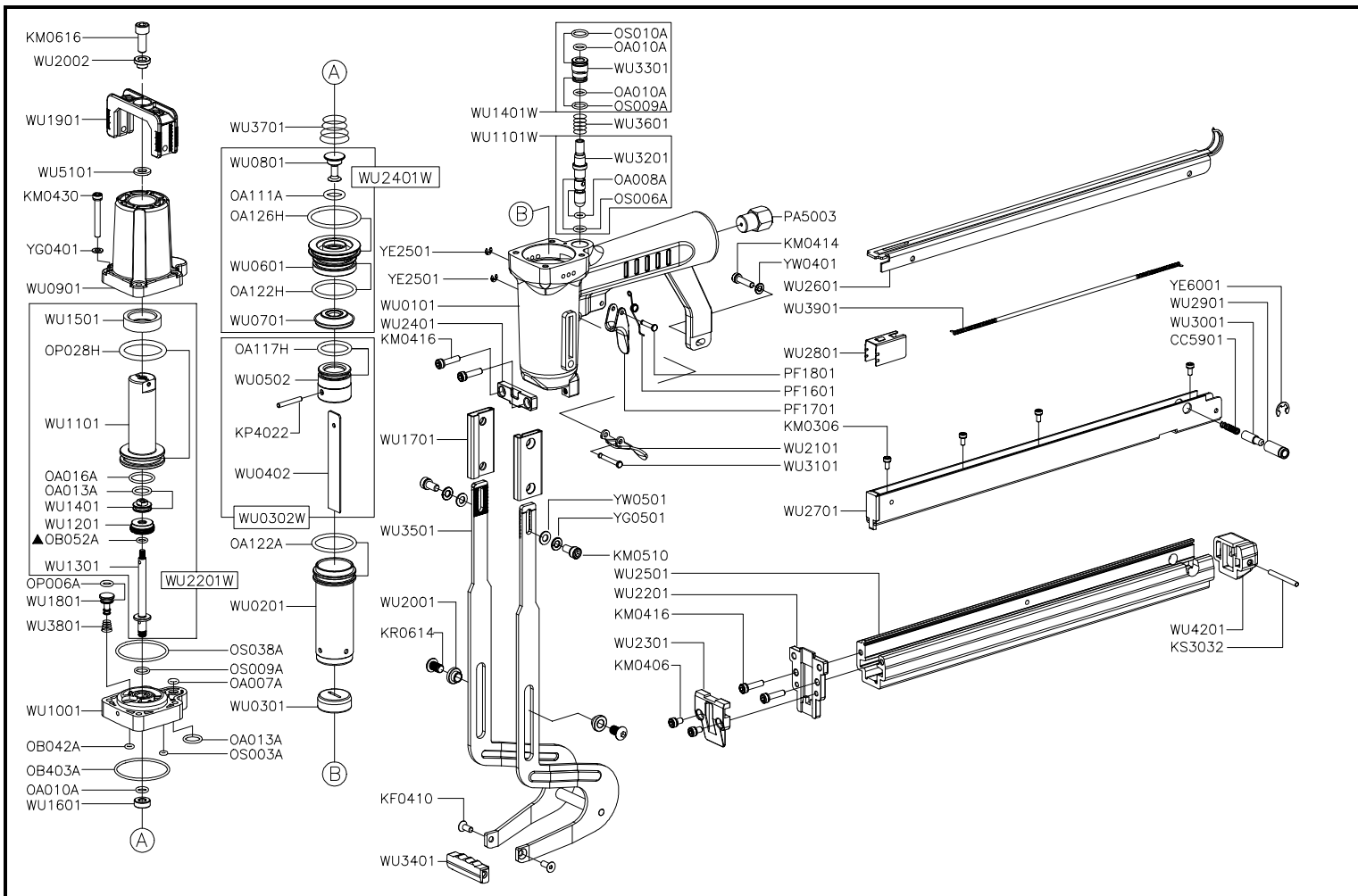

Part_No	Description	Spec	Qty	Part_No	Description	Spec	Qty	Part_No	Description	Spec	Qty
CC5901	COMPRESSION SPRING		1	OS010A	O-RING	S-10	1	WU2101	TRIGGER		1
KF0410	FLAT HD.BOLT	M4x0.7 - 10L	2	OS038A	O-RING	S-38	1	WU2201	GUIDE PLATE		1
KM0306	HEX.SOC.HD.BOLT	M3x0.5 - 6L	4	PA5003	COUPLING PLUG		1	WU2201W	HEAD VALVE CAP ASSY.		1
KM0406	HEX.SOC.HD.BOLT	M4x0.7 - 6L	2	PF1601	SPRING		1	WU2301	COVER PLATE(B)		1
KM0414	HEX.SOC.HD.BOLT	M4x0.7 - 14L	1	PF1701	SAFETY LEVER		1	WU2401	COVER PLATE(A)		1
KM0416	HEX.SOC.HD.BOLT	M4x0.7 - 16L	4	PF1801	PIN		1	WU2401W	HEAD VALVE SEAT ASSY.		1
KM0430	HEX.SOC.HD.BOLT	M4x0.7 - 30L	4	WU0101	BODY		1	WU2501	MAGAZINE SEAT		1
KM0510	HEX.SOC.HD.BOLT	M5x0.8 - 10L	2	WU0201	CYLINDER		1	WU2601	MAGAZINE CAP		1
KM0616	HEX.SOC.HD.BOLT	M6x1.0 - 16L	1	WU0301	BUMPER		1	WU2701	NAIL SEAT ASSY.		1
KP4022	PARALLEL PIN	∅ 4x22L	1	WU0302W	DRIVER ASSY.		1	WU2801	PUSHER		1
KR0614	BUTTON HD.BOLT	M6x1.0 - 14L	2	WU0402	DRIVER		1	WU2901	LATCH SEAT		1
KS3032	SPRING PIN	∅ 3-32L	1	WU0502	MAIN PISTON		1	WU3001	LATCH		1
OA007A	O-RING	ARP568-007	1	WU0601	HEAD VALVE SEAT		1	WU3101	PIN		1
OA008A	O-RING	ARP568-008	1	WU0701	GASKET		1	WU3201	TRIGGER VALVE STEM		1
OA010A	O-RING	ARP568-010	3	WU0801	VALVE		1	WU3301	TRIGGER VALVE SEAT		1
OA013A	O-RING	ARP568-013	2	WU0901	CYLINDER CAP		1	WU3401	PAWL		1
OA016A	O-RING	ARP568-016	1	WU1001	CAP		1	WU3501	SHORT JAW		1
OA111A	O-RING	ARP568-111	1	WU1101	WASHER ADJUSTMENT STROKE		1	WU3601	COMPRESSION SPRING		1
OA117H	O-RING	20.29x2.62	1	WU1101W	TRIGGER VALVE ASSY.		1	WU3701	COMPRESSION SPRING		1
OA122A	O-RING	ARP568-122	1	WU1201	REVERSAL CYLINDER RING NUT		1	WU3801	COMPRESSION SPRING		1
OA122H	O-RING	28.25x2.62	1	WU1301	REVERSAL CYLINDER SHAFT		1	WU3901	PULL SPRING		1
OA126H	O-RING	34.6x2.62	1	WU1401	MAIN PISTON		1	WU4201	COVER		1
OB042A	O-RING	3.5x1.8	1	WU1401W	TRIGGER VALVE CAP ASSY.		1	WU5101	FLAT WASHER		1
▲OB052A	O-RING	5x1.5	1	WU1501	BUMPER		1	YE2501	E-RING	∅ 2.5	2
OB403A	O-RING	39.5x1.5	1	WU1601	SCREW		1	YE6001	E-RING	∅ 6.0	1
OP006A	O-RING	P6	1	WU1701	RUBBER PLATE		2	YG0401	SPRING WASHER	∅ 4	4
OP028H	O-RING	27.7x3.5	1	WU1801	DIAPHRAGM VALVE		1	YG0501	SPRING WASHER	∅ 5	2
OS003A	O-RING	S-3	1	WU1901	FIXED SUPPORT		1	YW0401	FLAT WASHER	∅ 4	1
▲OS006A	O-RING	S-6	1	WU2001	WASHER		2	YW0501	FLAT WASHER	∅ 5	2
OS009A	O-RING	S-9	2	WU2002	WASHER		1				

★☆☆ If you need to order parts, please mark both Parts No. and Description. ☆☆☆